

MODEL NO : W028P18S1SI

MODEL VERSION: 01

SPEC VERSION : 2.9

ISSUED DATE: 2015-12-08

- Preliminary Specification
- Final Product Specification

Customer : _____

App oved by	Notes

LCD Confirmed :

Prepared by	Checked by	Approved by
Tiantian.Zhao	Xiaoxing.Ding	Feng.Qin

This technical specification is subjected to change without notice

Table of Contents

Table of Contents	2
Record of Revision.....	3
1 General Specifications	4
2 Input/Output Terminals	5
3 Absolute Maximum Ratings.....	6
4 Electrical Characteristics	7
5 Timing Chart.....	9
6 Optical Characteristics	15
7 Environmental / Reliability Test	18
8 Mechanical Drawing	19
9 Packing Drawing	20
10 Precautions for Use of LCD Modules.....	22

Record of Revision

Rev	Issued Date	Description	Editor
1.0	2010-12-29	First release	Kelly hu
1.1	2011-1-12	Updated pin15 definition	Kelly hu
2.0	2011-9-30	Final spec release.	Jin Zhao
2.1	2012-1-14	Updated supply voltage and IC PN	Jin Zhao
2.2	2012-1-19	Updated drawing and package info	Jin Zhao
2.3	2012-3-22	Update mechanical drawing	Jin Zhao
2.4	2012-4-6	Update mechanical drawing and label info	Jin Zhao
2.5	2012-4-17	Update mechanical drawing and label info	Jin Zhao
2.6	2012-7-30	Update mechanical drawing and label info	Ada Fu
2.7	2012-11-7	Add FPC drawing and update the label info(change Fixed number from 004T to 005T).	Ada Fu
2.8	2015-7-8	Update patent LED and update PN	Jin Zhao
2.9	2015-12-8	Add relative humidity	Tiantian Zhao

1 General Specifications

Feature		Spec
Display Spec.	Size	2.8"
	Resolution	240(RGB)x320
	Technology Type	a-si TFT
	Pixel Configuration	RGB Vertical Stripe
	Pixel pitch(mm)	0.153 x 0.153
	Display Mode	CT,NW
	Surface Treatment	Clear Type
	Viewing Direction	IPS
	Gray Scale Inversion Direction	-
Mechanical Characteristics	LCM (W x H x D) (mm)	50.00x69.20x2.4
	Active Area(mm)	43.20x57.60
	With /Without TSP	With RTP
	Matching Connection Type	18pin-0.8mm
	LED Numbers	4
	Weight (g)	20
Electrical Characteristics	Interface	SPI-4 WIRE
	Color Depth	262K
	Driver IC	ILI9341/ST7789

Note 1: Viewing direction for best image quality is different from TFT definition. There is a 180 degree shift.

Note 2: Requirements on Environmental Protection: Q/S0002

Note 3: LCM weight tolerance: $\pm 5\%$

2 Input/Output Terminals

Matched connector: 18pin-0.8mm

PIN No.	Symbol	Description
1	GND	Ground (接地脚)
2	RESET	LCM Reset pin Signal is active low. (屏复位脚, 低电平复位)
3	SCL	This pin is used serial interface clock in 4-wire 8-bit serial data interface. (4线串口的时钟信号) If not used, this pin should be connected to IOVCC or GND. (不用时接IOVCC或者接地)
4	D/C	- 4-line system (D/CX): Serves as command or parameter select. Fix to IOVCC level when not in use. (4线串口的寄存器/数据选择, 不用时接 IOVCC)
5	CS	Chip select pin ("Low" enable) (屏驱动芯片片选脚, 低电平有效)
6	SDA	Serial input signal. The data is applied on the rising edge of the SCL signal. If not used, fix this pin at IOVCC or GND (串口数据输入信号, 不用时接 IOVCC 或者接地)
7	SDO	Serial output signal. The data is outputted on the falling edge of the SCL signal. If not used, open this pin (串口数据输出信号, 不用时悬空)
8	GND	Ground (接地脚)
9	VCC	Power supply for LCM (2.8V-3.3V) (屏供电脚)
10	LEDA	Anode of Backlight (3.0V-3.4V Typical:3.2V) (背光正极供电脚, 电压范围:3.0-3.4V, 典型值:3.2V)
11	LEDK1	Cathode of Backlight (背光负极供电脚)
12	LEDK2	Cathode of Backlight (背光负极供电脚)
13	LEDK3	Cathode of Backlight (背光负极供电脚)
14	LEDK4	Cathode of Backlight (背光负极供电脚)
15	XL	Touch panel control pin (触摸屏控制脚)
16	YU	Touch panel control pin (触摸屏控制脚)
17	XR	Touch panel control pin (触摸屏控制脚)
18	YD	Touch panel control pin (触摸屏控制脚)

Note1,, Please add the FPC connector type and matched one if necessary .

3 Absolute Maximum Ratings

GND=0V

Item	Symbol	MIN	MAX	Unit	Remark
Power Voltage	VCC	-0.3	4.6	V	Note1
Input voltage	V _{IN}	-0.3	4.6	V	
Operating Temperature	Top	-20	70	°C	
Storage Temperature	Tst	-30	80	°C	
Relative Humidity Note2	RH	--	--95	%	Ta<<40°C
		--	--85	%	40°C<Ta<<50°C
		--	--55	%	50°C<Ta<<60°C
		--	--36	%	60°C<Ta<<70°C
		--	--24	%	70°C<Ta<<80°C
Absolute Humidity	AH	--	--70	g/m ³	Ta>70°C

Table 3 Absolute Maximum Ratings

Note1: Input voltage include R0~R5, G0~G5, B0~B5, Dotclk, Hsync, Vsync, Enable, R/L, U/D.

Note2: Ta means the ambient temperature.

It is necessary to limit the relative humidity to the specified temperature range.

Condensation on the module is not allowed.

4 Electrical Characteristics

4.1 LCD Module

GND=0V, Ta=25?

Item	Symbol	MIN	TYP	MAX	Unit	Remark
Logic Supply Voltage	IOVCC	2.5	2.8	3.3+/-10%	V	
Analog Supply Voltage	VCC	2.5	2.8	3.3+/-10%	V	
Input Signal Voltage	High Level	0.7 IOVCC	-	IOVCC	V	
	Low Level	-	-	0.3 IOVCC	V	
Output Signal Voltage	High Level	0.8 IOVCC	-	-	V	
	Low Level	-	-	0.2 IOVCC	V	
(Panel+LSI) Power Consumption	Black Mode	-	30	36	mW	
	Sleeping Mode	-	0.047	0.057	mW	

Table 4.1 LCD module electrical characteristics

4.2 Backlight Unit

Ta=25?

Item	Symbol	MIN	TYP	MAX	Unit	Remark
Forward Current	I_F	-	15	-	mA	One LED
Forward Voltage	V_F	(2.9)	3.2	(3.4)	V	One LED
Backlight Power Consumption	W_{BL}	-	192	-	mW	4 LEDs
Lifetime	T	-	20000	-	Hr	One LED

Table 4.2.1 backlight unit electrical characteristics

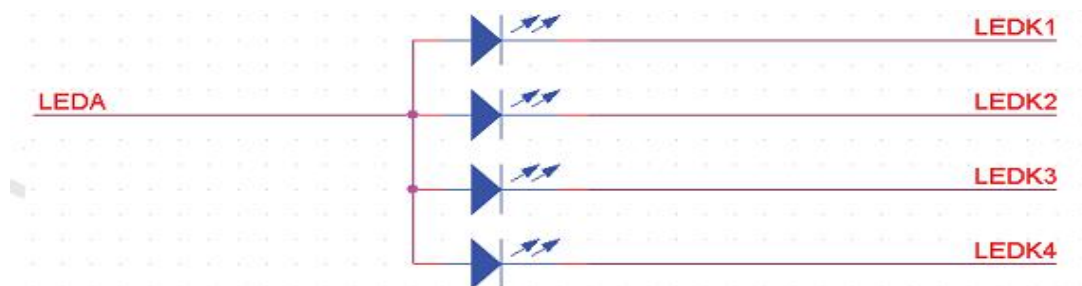
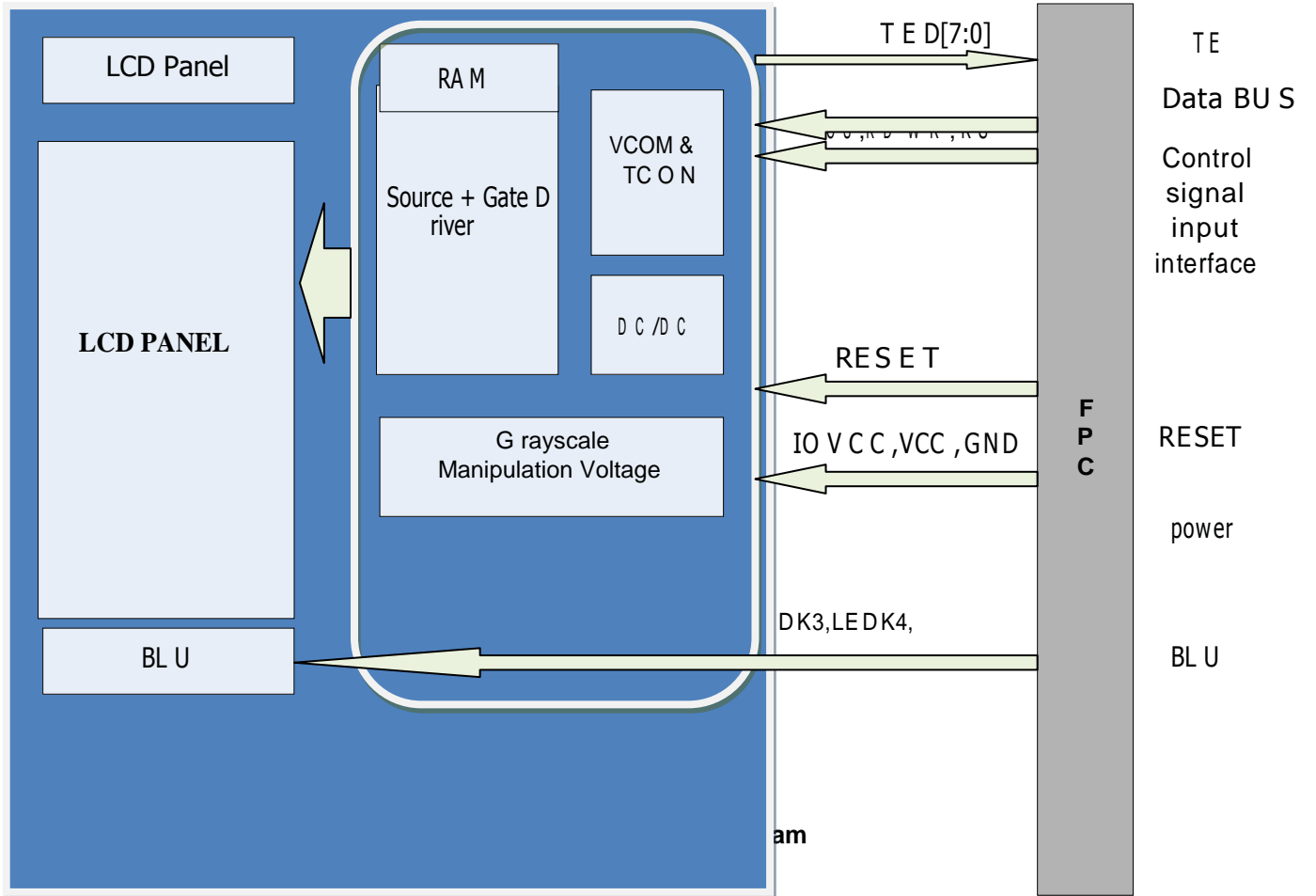

Figure 4.2.1 LED backlight circuit

4.3 Block Diagram



5 Timing Chart

5.1 Timing Parameter

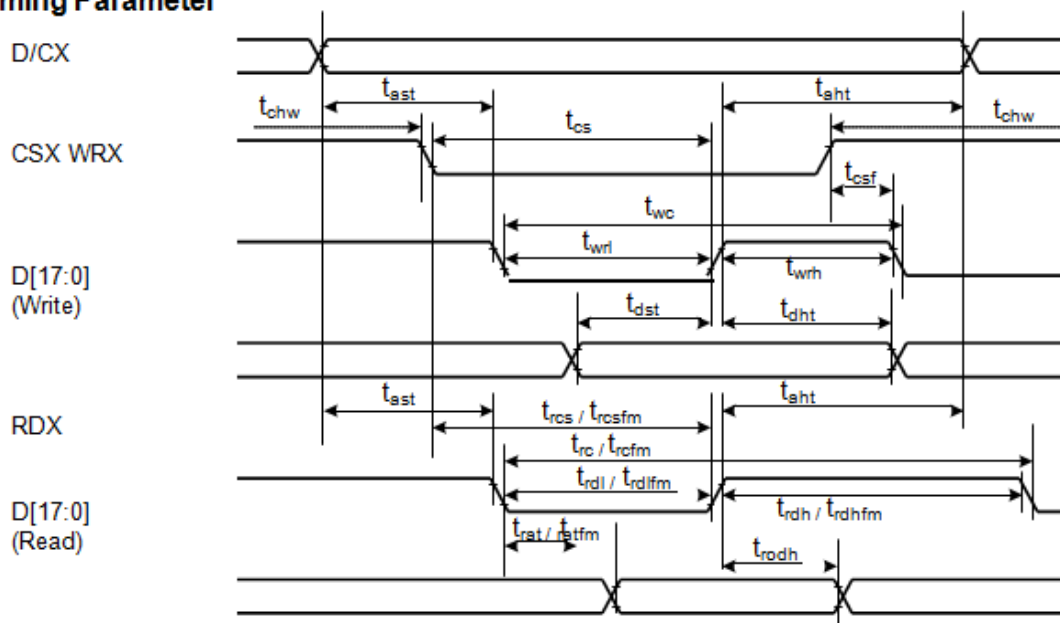

Figure 5.1 Parallel interface characteristics

Signal	Symbol	Parameter	min	max	Unit	Description
DCX	tast	Address setup time	0	-	ns	
	taht	Address hold time (Write/Read)	0	-	ns	
CSX	tchw	CSX "H" pulse width	0	-	ns	
	tcs	Chip Select setup time (Write)	15	-	ns	
	trcs	Chip Select setup time (Read ID)	45	-	ns	
	trcsfm	Chip Select setup time (Read FM)	355	-	ns	
	tcsf	Chip Select Wait time (Write/Read)	10	-	ns	
	WRX	twc	Write cycle	66	-	ns
twrh		Write Control pulse H duration	15	-	ns	
twrl		Write Control pulse L duration	15	-	ns	
RDX (FM)	trcfm	Read Cycle (FM)	450	-	ns	
	trdhfm	Read Control H duration (FM)	90	-	ns	
	trdlfm	Read Control L duration (FM)	355	-	ns	
RDX (ID)	trc	Read cycle (ID)	160	-	ns	
	trdh	Read Control pulse H duration	90	-	ns	
	trdl	Read Control pulse L duration	45	-	ns	
D[17:0], D[15:0], D[8:0], D[7:0]	tdst	Write data setup time	10	-	ns	For maximum CL=30pF For minimum CL=8pF
	tdht	Write data hold time	10	-	ns	
	trat	Read access time	-	40	ns	
	tratfm	Read access time	-	340	ns	
	trod	Read output disable time	20	80	ns	

Note: $T_a = -30$ to 70 °C, $V_{DDI}=1.65V$ to $3.3V$, $V_{CI}=2.5V$ to $3.3V$, $V_{SS}=0V$

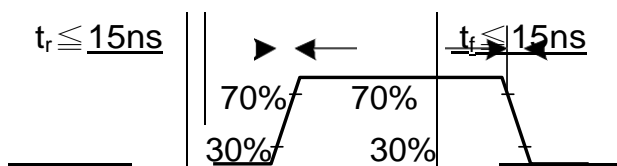

Table 5.1 timing parameter

5.2. Register write/read timing

a. Write to register

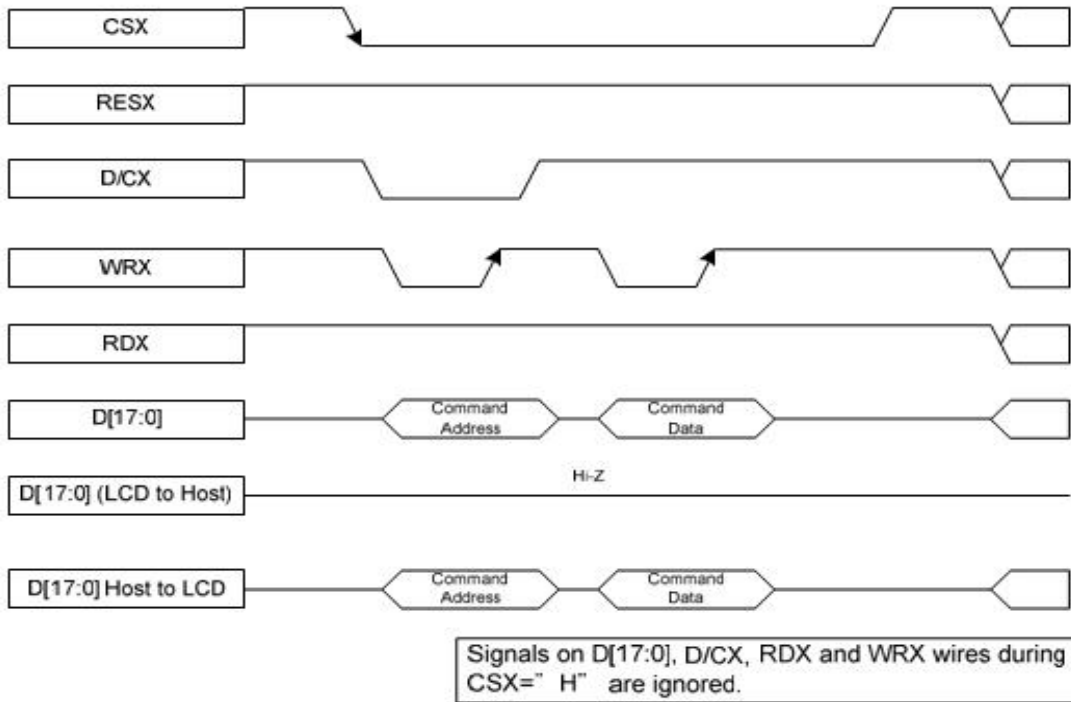
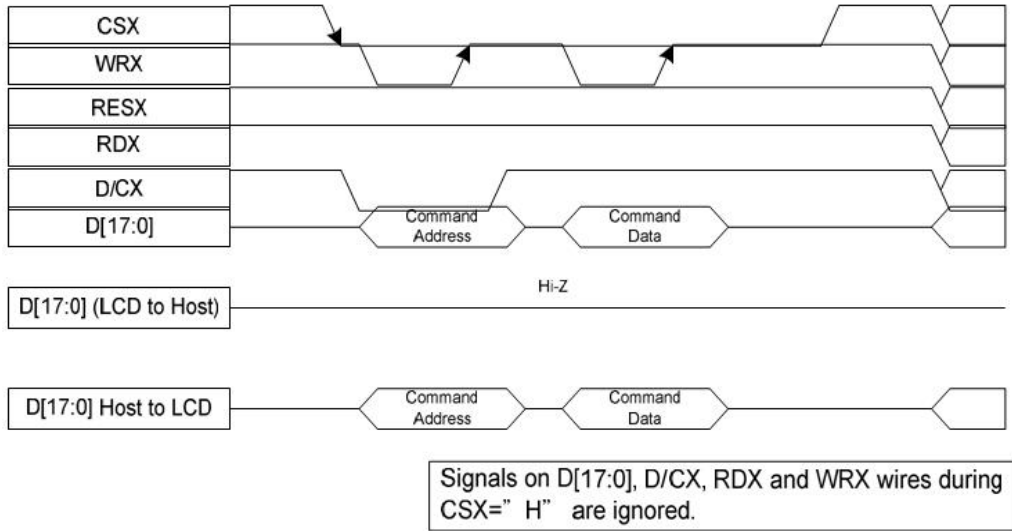

Figure 5.2.1 Register write timing in parallel bus system interface (for I80 series MPU)

b. Read from register



Note: Read data is only valid when the D/CX input is pulled high. If D/CX is driven low during read then the display information outputs will be High-Z.

Figure 5.2.2 Register read timing in parallel bus system interface (for I80 series MPU)

CS timings

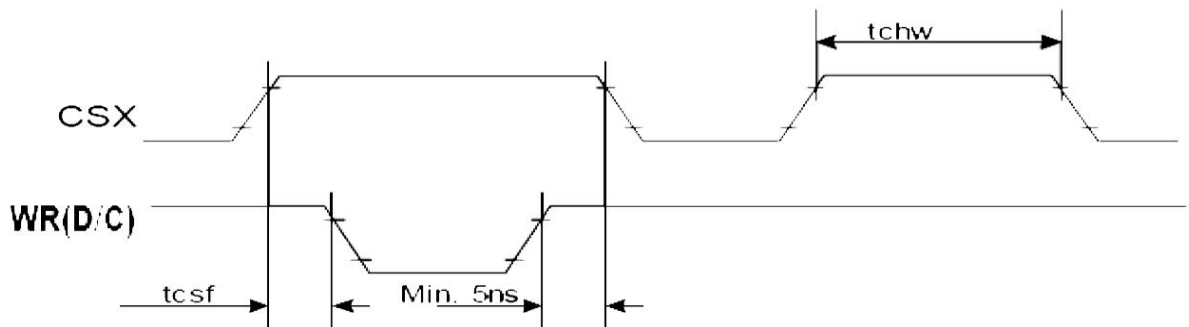

Figure 5.2.3 Chip selection timing

Write to read or read to write timings

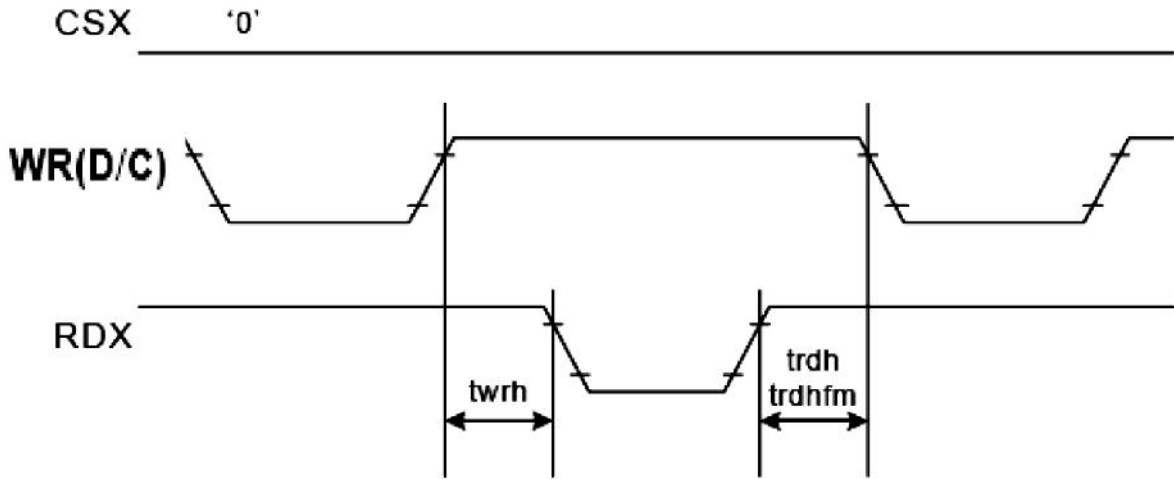
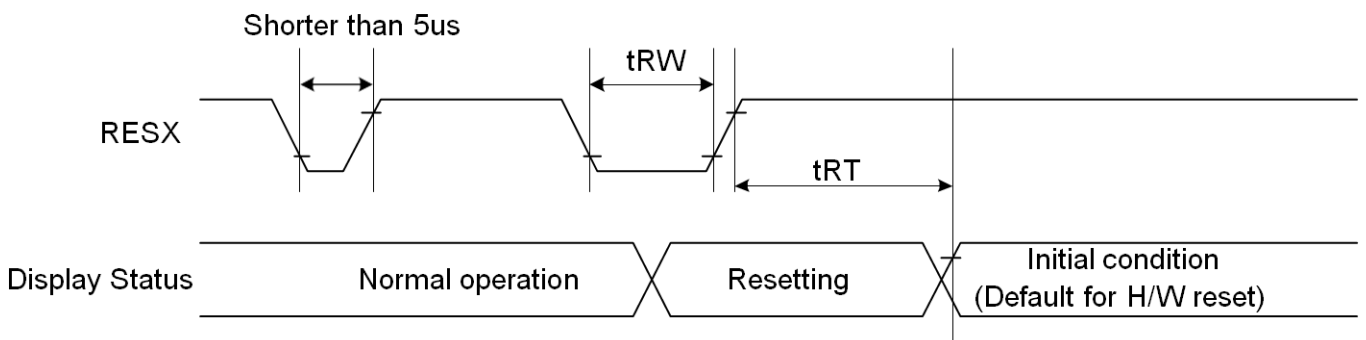

Figure 5.2.4 Write-to-read and read-to-write timing

5.3 Reset Timing Characteristics



Signal	Symbol	Parameter	Min	Max	Unit
RESX	tRW	Reset pulse duration	10		uS
	tRT	Reset cancel		5 (note 1,5)	mS
				120 (note 1,6,7)	mS

Figure 5.3 RESET Timing

5.4 Power on Sequence

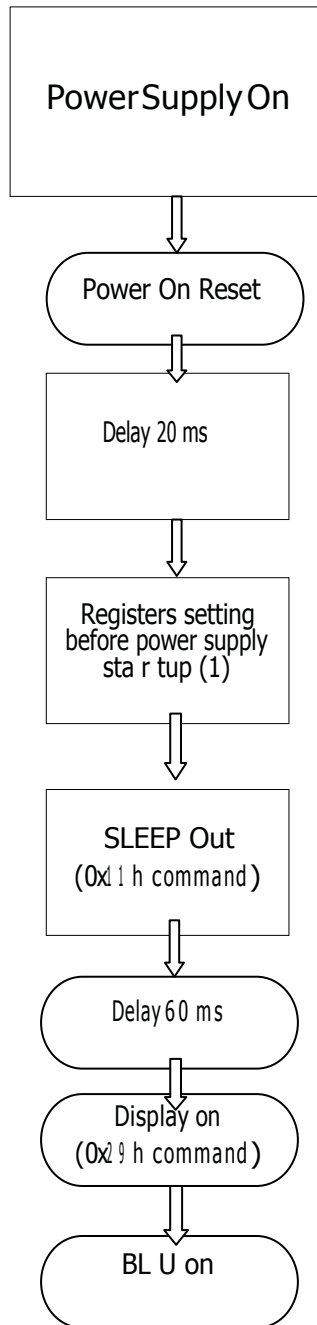

5.5 Power off Sequence

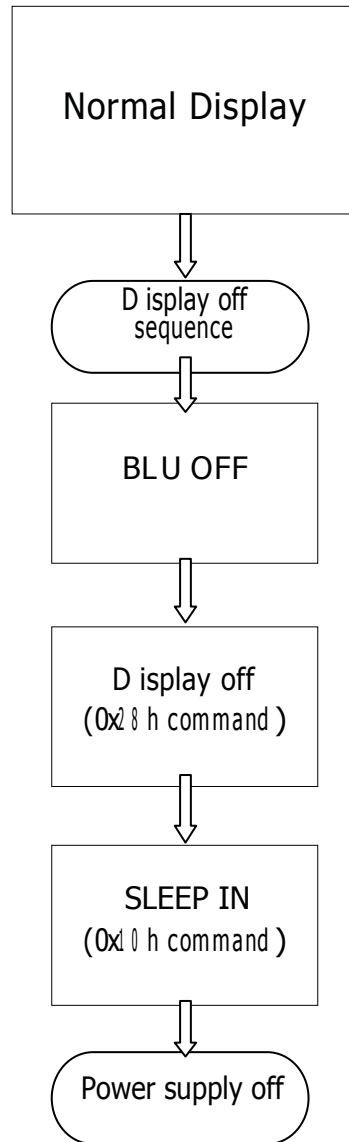

6. Optical Characteristics

Item	Symbol	Condition	Min	Typ	Max	Unit	Remark
View Angles	0T	CRŠ10	60	70	60	Degree	Note2,3
	0B		60	70	60		
	0L		60	70	60		
	0R		60	70	60		
Contrast Ratio	CR	0=0°	400	500	400		Note 3
Response Time	T _{ON}	25°C		20	30	ms	Note 4
	T _{OFF}						
Chromaticity	White	Backlight is on	x	0.236	0.286	0.336	Note 1,5
			y	0.261	0.311	0.361	
	Red		x	0.530	0.580	0.630	Note 1,5
			y	0.270	0.320	0.370	
	Green		x	0.288	0.338	0.388	Note 1,5
			y	0.531	0.581	0.631	
	Blue		x	0.101	0.151	0.201	Note 1,5
			y	0.048	0.098	0.148	
Uniformity	U		-	80%		%	Note 6
NTSC			-	50%		%	Note 5
Luminance	L		180	200		cd/m ²	Note 7

Test Conditions:

1. I_F= 60mA, and the ambient temperature is 25°C.
2. The test systems refer to Note 1 and Note 2.

Note 1: Definition of optical measurement system.

The optical characteristics should be measured in dark room. After 5 Minutes operation, the optical properties are measured at the center point of the LCD screen. All input terminals LCD panel must be ground when measuring the center area of the panel.

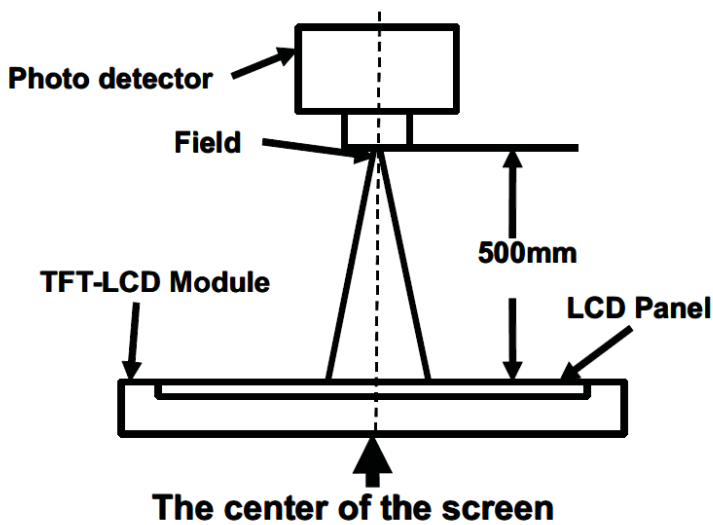

Item	Photo detector	Field
Contrast Ratio	SR-3A	1°
Luminance		
Chromaticity		
Lum Uniformity	BM-7A	2°
Response Time		

Note 2: Definition of viewing angle range and measurement system.

viewing angle is measured at the center point of the LCD by CONOSCOPE(ergo-80).

Note 3: Definition of contrast ratio

“White state “: The state is that the LCD should drive by V_{white} .

“Black state”: The state is that the LCD should drive by V_{black} .

V_{white}: To be determined V_{black}: To be determined.

Note 4: Definition of Response time

The response time is defined as the LCD optical switching time interval between “White” state and “Black” state. Rise time (T_{ON}) is the time between photo detector output intensity changed from 90% to 10%. And fall time (T_{OFF}) is the time between photo detector output intensity changed from 10% to 90%.

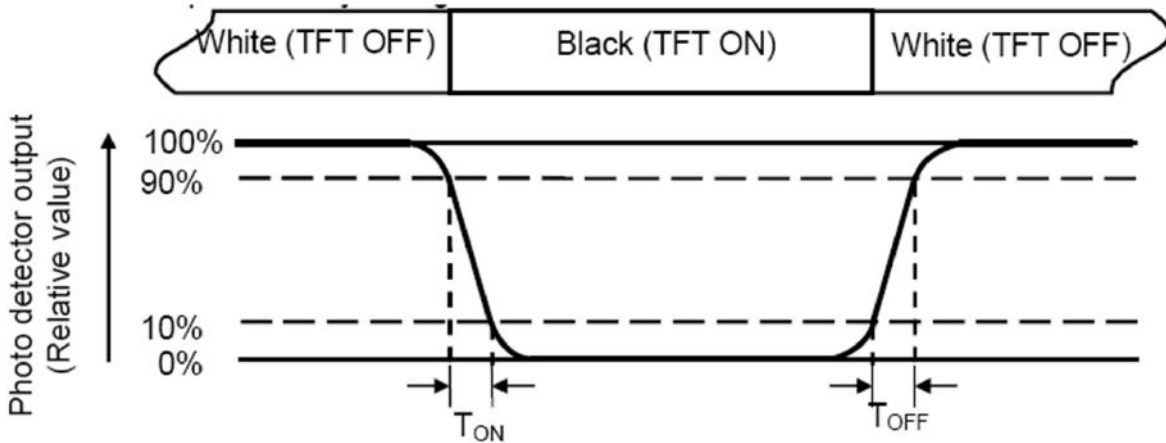

Note 5: Definition of color chromaticity (CIE1931)

Color coordinates measured at center point of LCD.

Note 6: Definition of Luminance Uniformity

Active area is divided into 9 measuring areas (Refer Fig. 2). Every measuring point is placed at the center of each measuring area.

$$\text{Luminance Uniformity (U)} = L_{\min} / L_{\max}$$

L-----Active area length W----- Active area width

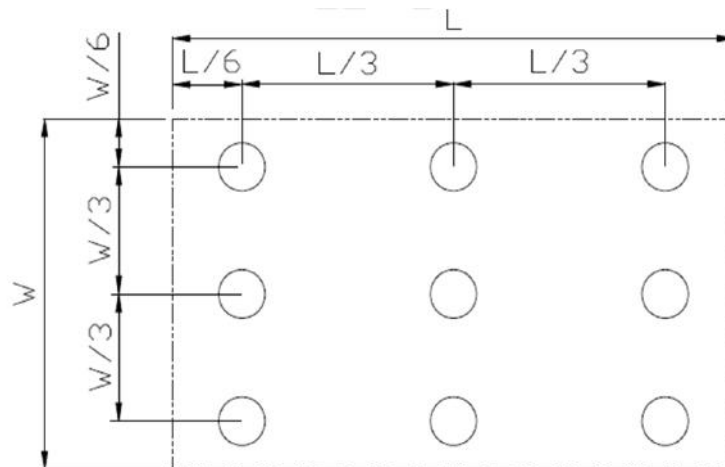

L_{max}: The measured Maximum luminance of all measurement position.

L_{min}: The measured Minimum luminance of all measurement position.

Note 7: Definition of Luminance:

Measure the luminance of white state at center point.

7 Environmental I Reliability Test

No	Test Item	Condition	Remarks
1	High Temperature Operation	Ts=+70°C 240hrs	IEC60068-2-1:2007 GB2423.2-2008
2	Low Temperature Operation	Ta=-20°C, 240hrs	IEC60068-2-1:2007 GB2423.1-2008
3	High Temperature Storage	Ta=+80°C, 240hrs	IEC60068-2-1:2007 GB2423.2-2008
4	Low Temperature Storage	Ta=-30°C, 240hrs	IEC60068-2-1:2007 GB2423.1-2008
5	Storage at High Temperature and Humidity	Ta=+60°C, 90% RH 240 hours	IEC60068-2-78 :2001 GB/T2423.3—2006
6	Thermal Shock (non-operation)	-30°C 30 min~+70°C 30 min, Change time:5min, 20 Cycles	Start with cold temperature, End with high temperature, IEC60068-2-14:1984,G B2423.22-2002
7	ESD	C=150pF, R=330K> 5points/panel Air:±8KV, 5times; Contact:±4KV, 5 times; (Environment: 15°C~35°C, 30%~60%, 86Kpa~106Kpa)	IEC61000-4-2:2001 GB/T17626.2-2006
8	Vibration Test	Frequency range:10~55Hz, Stroke:1.5mm Sweep:10Hz~55Hz~10Hz 2 hours for each direction of X.Y.Z. (6 hours for total)(Package condition)	IEC60068-2-6:1982 GB/T2423.10—1995
9	Mechanical Shock (Non OP)	60G 6ms, ±X,±Y,±Z 3times, for each direction	IEC60068-2-27:1987 GB/T2423.5—1995
10	Package Drop Test	Height:80 cm, 1 corner, 3 edges, 6 surfaces	IEC60068-2-32:1990 GB/T2423.8—1995

Note1: Ts is the temperature of panel's surface.

Note2: Ta is the ambient temperature of sample.

Note3: Before cosmetic and function test, the product must have enough recovery time, at least 2 hours at room temperature.

Note 4: In the standard condition, there shall be no practical problem that may affect the display function. After the reliability test, the product only guarantees operation, but don't guarantee all of the cosmetic specification.

8 Mechanical Drawing

技术要求:

- 1) 液晶显示模式: 2.8" TFT Transmissive
- 2) 显示颜色: 262K
- 3) 视角: 12.0° CLOCK
- 4) 点阵: 240(RGB)X320 DOTS
- 5) PIXEL PITCH: 0.18 X 0.18 mm
- 6) 驱动芯片型号: IL9341
- 7) 背光: LED WHITE(K4), 并联
- 8) 工作温度: -20° C ~ 70° C
- 9) 贮存温度: -30° C ~ 80° C

产品符合: ROHS标准

Top View Dimensions: 50.00 ± 0.2 (LCM), 49.60 ± 0.2 (TP), 43.20 (LCD A, A), 69.20 ± 0.2 (LCM), 68.40 ± 0.2 (TP), 57.60 (LCD A, A), 2.60, 19.16, 17.36, 1.40 ± 0.5, 6.30 ± 0.5, 1.70 ± 0.3, 15.60, 38.60 ± 0.2, 6.14, 1.40, 3.60 ± 0.05, 0.80, 3.55 ± 0.1, 2.40 max.

Side View Dimensions: 2.60, 0.80, 3.55 ± 0.1, 2.40 max.

Bent View Dimensions: 68.25, 49.04, 2.0, 42.78, 12.00, 36.99, 1.60, 2.20 ± 0.3, 2-R-0.50, 5.50, 3.00, 32.50 ± 0.1, 17.76.

BL CIRCUIT DIAGRAM

弯折示意图
展开出货

PIN	SYMBOL
1	GND
2	RESET
3	SCL
4	D/C
5	CS
6	SDA
7	SDD
8	GND
9	VCC
10	LEDA
11	LEBK1
12	LEBK2
13	LEBK3
14	LEBK4
15	XL
16	YU
17	XR
18	YD

产品型号: LCDT281341801		确认:	
LCM外形图			
版本号: v0.0	单位: MM	审核:	
日期: 2015.04.25	比例: 1:1	设计:	
UNMARKED TOLERANCE: ±0.20 mm		页码:	1 OF 1

深圳市艾斯迪科技有限公司

第三视角:

9 Precautions for Use of LCD Modules

8.1 Handling Precautions

8.1.1 The display panel is made of glass. Do not subject it to a mechanical shock by dropping it from a high place, etc.

8.1.2 If the display panel is damaged and the liquid crystal substance inside it leaks out, be sure not to get any in your mouth, if the substance comes into contact with your skin or clothes, promptly wash it off using soap and water.

8.1.3 Do not apply excessive force to the display surface or the adjoining areas since this may cause the color tone to vary.

8.1.4 The polarizer covering the display surface of the LCD module is soft and easily scratched. Handle this polarizer carefully.

8.1.5 If the display surface is contaminated, breathe on the surface and gently wipe it with a soft dry cloth. If still not completely clear, moisten cloth with one of the following solvents:

- Isopropyl alcohol
- Ethyl alcohol

Solvents other than those mentioned above may damage the polarizer. Especially, do not use the following:

- Water
- Ketone
- Aromatic solvents

8.1.6 Do not attempt to disassemble the LCD Module.

8.1.7 If the logic circuit power is off, do not apply the input signals.

8.1.8 To prevent destruction of the elements by static electricity, be careful to maintain an optimum work environment.

8.1.8.1 Be sure to ground the body when handling the LCD Modules.

8.1.8.2 Tools required for assembly, such as soldering irons, must be properly ground.

8.1.8.3 To reduce the amount of static electricity generated, do not conduct assembly and other work under dry conditions.

8.1.8.4 The LCD Module is coated with a film to protect the display surface. Be care when peeling off this protective film since static electricity may be generated.

8.2 Storage precautions

8.2.1 When storing the LCD modules, avoid exposure to direct sunlight or to the light of fluorescent lamps.

8.2.2 The LCD modules should be stored under the storage temperature range. If the LCD modules will be stored for a long time, the recommend condition is:

Temperature : 0? ~ 40? Relatively humidity: “80%

8.2.3 The LCD modules should be stored in the room without acid, alkali and harmful gas.

8.3 Transportation Precautions

The LCD modules should be no falling and violent shocking during transportation, and also should avoid excessive press, water, damp and sunshine.