

Product Specification

Customer: _____

Model Name: W035P54S1RN

Date: _____

Version: _____

Preliminary Specification

Final Specification

For Customer's Acceptance

Approved by	Comment

Approved by	Reviewed by	Prepared by

Contents

1.Record of Revision.....	3
2 .General Specifications.....	4
3 .Input/Output Terminals	5
4. Absolute Maximum Ratings	6
5 .Electrical Characteristics	6
6 .Interface Timing.....	7
7. Optical Characteristics	11
8 . Environmental / Reliability Tests	14
9. Mechanical Drawing.....	15
10.Packing.....	20
11. Precautions For Use of LCD modules	21



1. Record of Revision

Version	Revise Date	Content	Editor
1.0	2016/06/12	First Release.	Rich Liang

2 General Specifications

	Feature	Spec
Characteristics	LCD Size	3.5inch
	Display Format	320 (RGB) × 240
	Interface	24-bit RGB/SERIAL RGB/CCIR656/CCIR601
	Color Depth	16.7M
	Technology type	a-Si
	Display Spec.	0.073 x 0.219
	Display Mode	Normally White
	Driver IC	HX8238D
	Surface Treatment	Haze 20%
	Viewing Direction	12 O'clock
	Gray Viewing Direction	6 O'clock
Mechanical	LCM (W x H x D) (mm)	76.90*63.9*3.26
	Active Area(mm)	70.08 x 52.56
	With /Without TSP	Without TSP
	Weight (g)	TBD
	LED Numbers	6 LEDs

Note 1: Viewing direction is following the data which measured by optics equipment.

Note 2: Requirements on Environmental Protection: RoHS

Note 3: LCM weight tolerance: +/- 5%



3 Input/Output Terminals

No.	Symbol	Description
1,2	VBL-	Backlight LED Cathode
3,4	VBL+	Backlight LED Anode.
5	YU	Touch panel up side
6	XR	Touch panel right side
7	NC	NC
8	RESET	Reset Signal pin ("Low" is enable)
9	SPENB	Chip select
10	SPCK	Serial Clock.
11	SPDA	Serial Data
12-19	B0~B7	Data bus
20-27	G0~G7	Data bus
28-35	R0~R7	Data bus
36	HSYNC	Line Synchronous Signal
37	VSYNC	Frame Synchronous Signal
38	DOTCLK	Dot-clock signal and oscillator source
39-40	NC	NC
41-42	VDD	Power supply for logic operation
43	YD	Touch panel bottom side
44	XL	Touch panel left side
45-47	NC	
48	IF2	Control the input data format/floating
49	IF1	Control the input data format
50	IF0	Control the input data format
51	NC	NC
52	DEN	Display enable signal
53-54	GND	System Ground

4 Absolute Maximum Ratings

Item	Symbol	MIN	MAX	Unit	Remark
Supply Voltage	V_{DD}	-0.3	5.0	V	
Input Signal Voltage	V_{in}	-0.3	$V_{DD}+0.3$	V	
Logic Output Voltage	V_{OUT}	-0.3	$V_{DD}+0.3$	V	
Operating Temperature	T_{OPR}	-20	70	°C	
Storage Temperature	T_{STG}	-30	80	°C	

5 Electrical Characteristics

5.1 Operating conditions:

Parameter	Symbol	MIN	TYP	MAX	Unit	Remark
Power Voltage	V_{CC}	3.0	3.3	3.6	V	
Digital Operation Current	I_{CC}		8.6		mA	
Gate On Power	V_{COMH}	2.5	13.9	4.5	V	
Gate Off Power	V_{GH}	-	-13.6	15	V	
Vcom High Voltage	V_{comH}	-	3.9	-	V	Note1
Vcom low Voltage	V_{comL}	-	-1.2	-	V	Note1
Vcom level max	V_{comA}	-	-	6	V	

Note1. V_{comH} & V_{comL} : Adjust the color with gamma data. V_{p-p} should be higher than 4V. (Option 5V)

Note: Please power on following the sequence V_{CC} V_{DD}

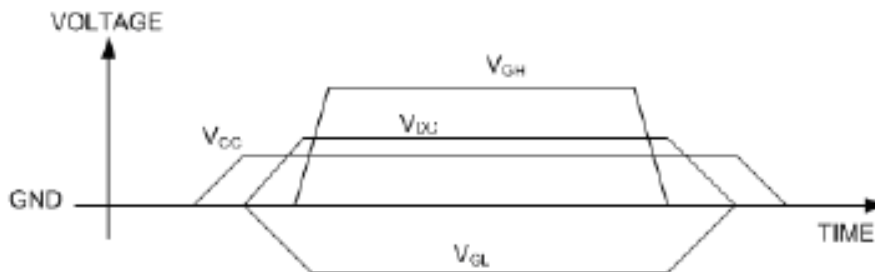

5.2 Driving Backlight

Item	Symbol	MIN	TYP	MAX	Unit	Remark
LED current	I_F	-	20	25	mA	Note 1 Note 2,3
Power Consumption			400	420	mW	
LED Voltage	V_F	18.6	19.8	21	V	
LED Life Time	W_{BL}	-	TBD	-	Hr	

Note 1 : There are 1 Groups LED



Note 2 : $T_a = 25^\circ\text{C}$

Note 3 : Brightness to be decreased to 50% of the initial value

6 Interface Timing

6.1 AC Electrical Characteristics

Digital Parallal RGB interface

Signal	Item	Symbol	Min	Typ	Max	Unit
Dclk	Frequency	Tosc	-	156	-	ns
	High Time	Tch	-	78	-	ns
	Low Time	Tcl	-	78	-	ns
Data	Setup Time	Tsu	12	-	-	ns
	Hold Time	Thd	12	-	-	ns
Hsync	Period	TH	-	408	-	Tosc
	Pulse Width	THS	5	30	-	Tosc
	Back-Porch	Thb		38		Tosc
	Display Period	TEP	-	320	-	Tosc
	Hsync-den time	THE	36	68	88	Tsoc
	Front-Porch	Thf	-	20	-	Tosc
Vsync	Period	Tv	-	262	-	TH
	Pulse Width	Tvs	1	3	5	TH
	Back-Porch	Tvb	-	15	-	TH
	Display Period	Tvd	-	240	-	TH
	Front-Porch	Tvf	2	4	-	TH

- Note:
1. $Thp + Thb = 68$, the user is make up by yourself.
 2. $Tv = Tvs + Tvb + Tvd + Tvf$, the user is make up by yourself.
 3. When SYNC mode is used, 1st data start from 68th Dclk after Hsync falling



深圳市五和天成科技有限公司

Digital Serial RGB interface

Signal	Item	Symbol	Min	Typ	Max	Unit
Dclk	Frequency	Tosc	-	52	-	ns
	High Time	Tch	-	78	-	ns
	Low Time	Tcl	-	78	-	ns
Data	Setup Time	Tsu	12	-	-	ns
	Hold Time	Thd	12	-	-	ns
Hsync	Period	TH	-	1224	-	Tosc
	Pulse Width	THS	5	90	-	Tosc
	Back-Porch	Thb		114		Tosc
	Display Period	TEP	-	960	-	Tosc
	Hsync-den time	THE	108	204	264	
	Front-Porch	Thf	-	60	-	Tosc
Vsync	Period	Tv	-	262	-	TH
	Pulse Width	Tvs	1	3	5	TH
	Back-Porch	Tvb	-	15	-	TH
	Display Period	Tvd	-	240	-	TH
	Front-Porch	Tvf	2	4	-	TH

- Note: 1. $T_{hp} + T_{hb} = 204$, the user is make up by yourself.
 2. $T_v = T_{vs} + T_{vb} + T_{vd} + T_{vf}$, the user is make up by yourself.
 3. When SYNC mode is used, 1st data start from 204th Dclk after Hsync falling

CCIR601/656 Interface

Signal	Item	Symbol	Min	Typ	Max	Unit
Dclk	Frequency	Tosc	-	37	-	ns
	High Time	Tch	-	78	-	ns
	Low Time	Tcl	-	78	-	ns
Data	Setup Time	Tsu	12	-	-	ns
	Hold Time	Thd	12	-	-	ns

6.2 Waveform

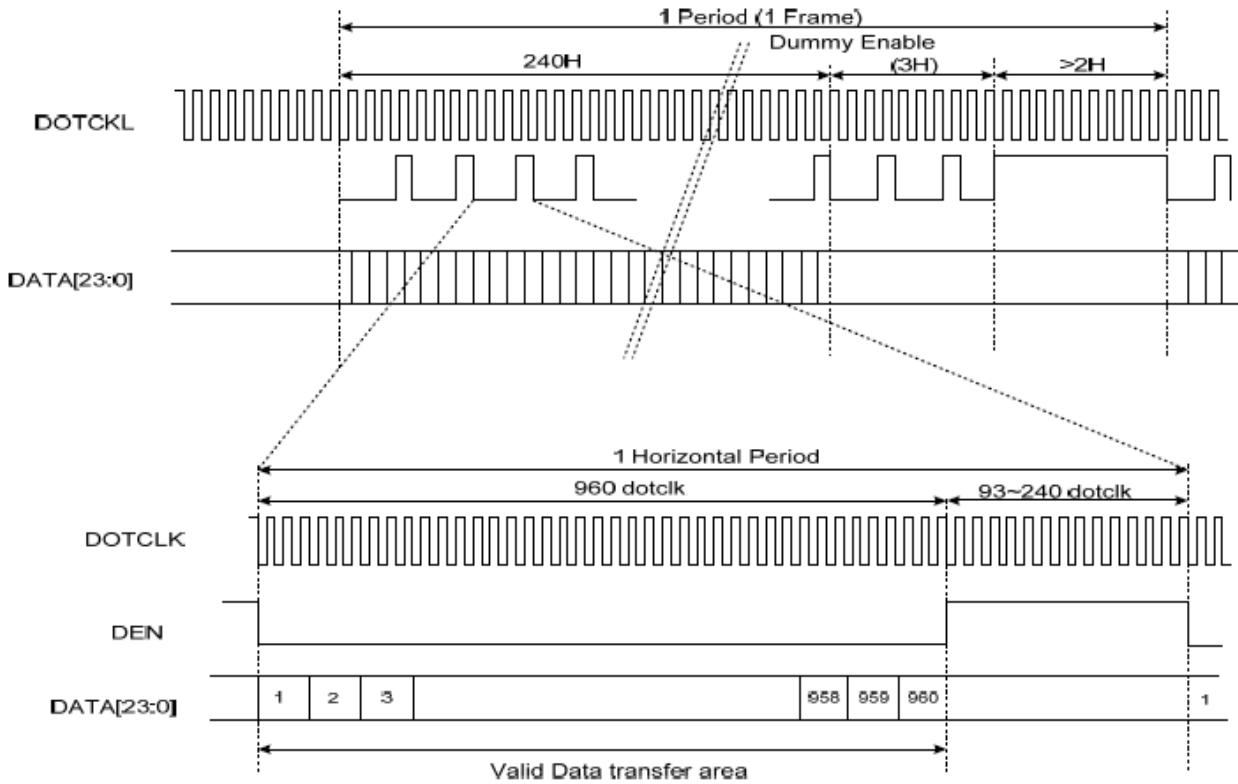
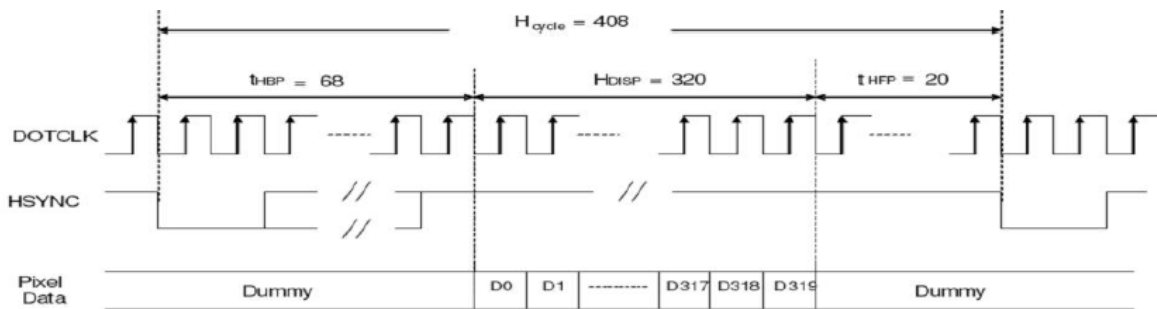
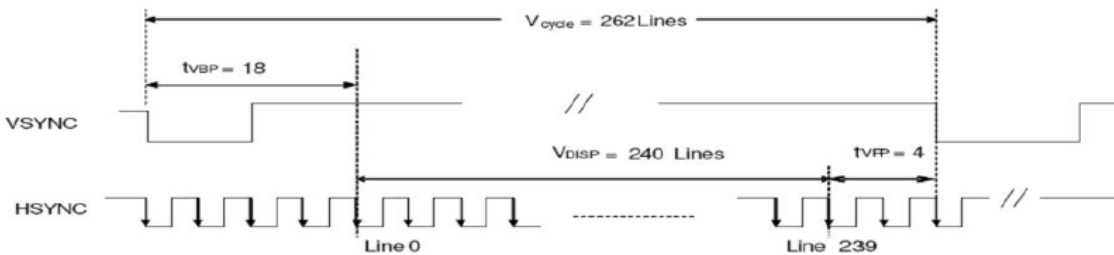

Figure 3 Data Transaction Timing in Serial RGB (8 bit) Interface (DE Mode)



a) Horizontal Data Transaction Timing



b) Vertical Data Transaction Timing

Figure 3 Data Transaction Timing in Parallel RGB (24 bit) Interface (SYNC Mode)

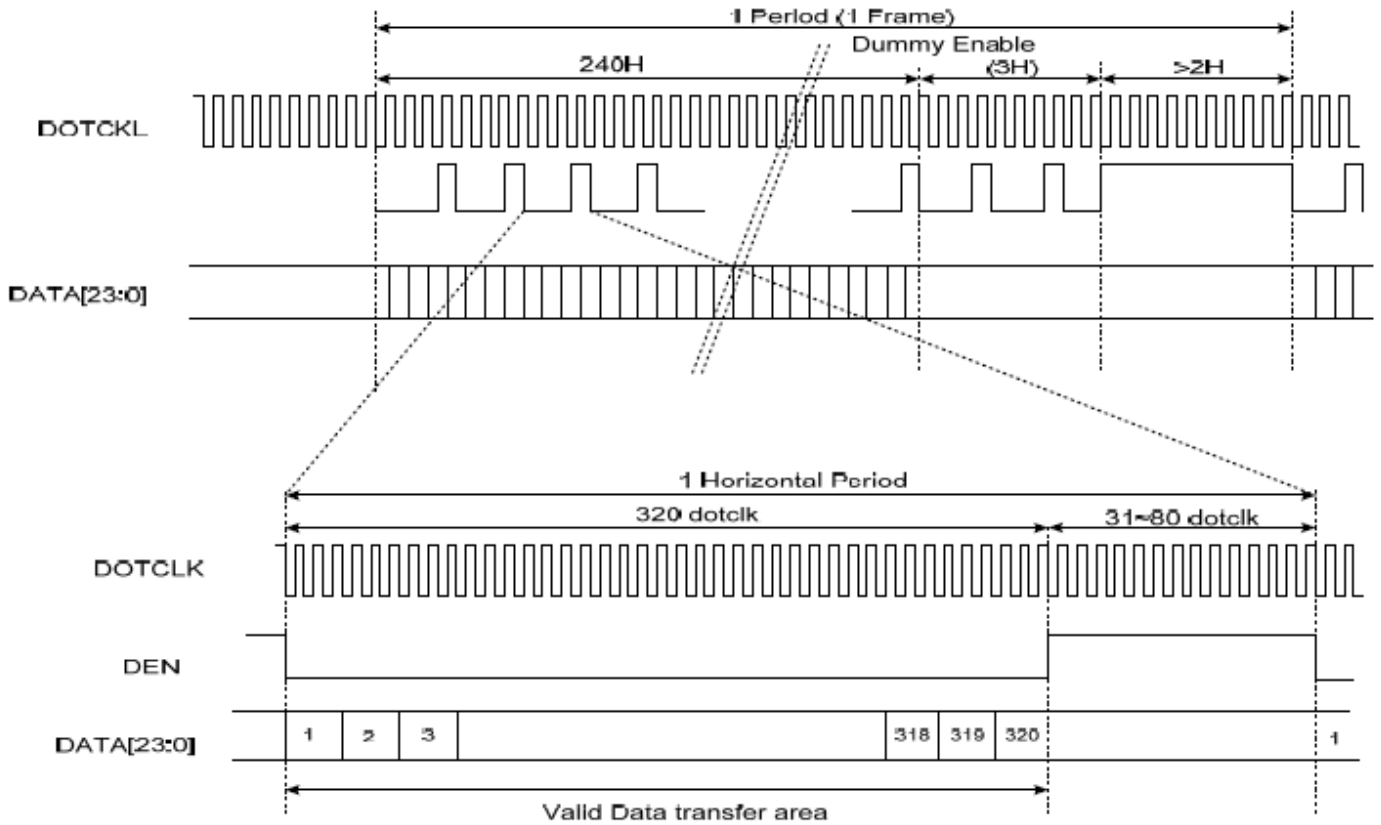

Figure 4 Data Transaction Timing in Parallel RGB (24 bit) Interface (DE Mode)

6.3 Clock and Sync waveforms

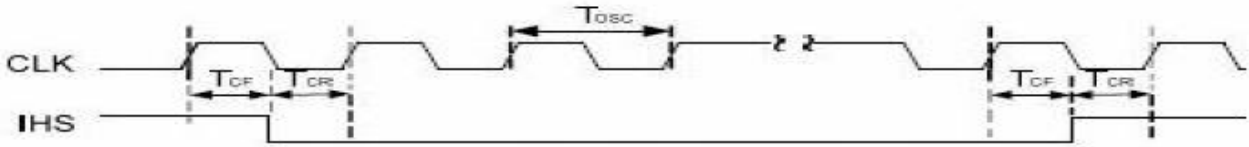

Figure 6 CLK and IHS timing waveform

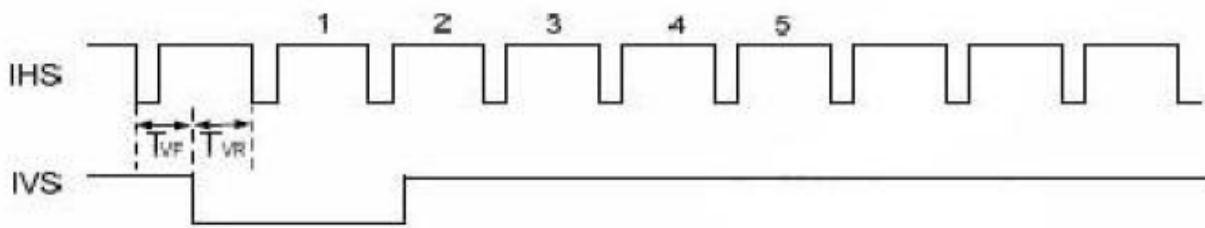
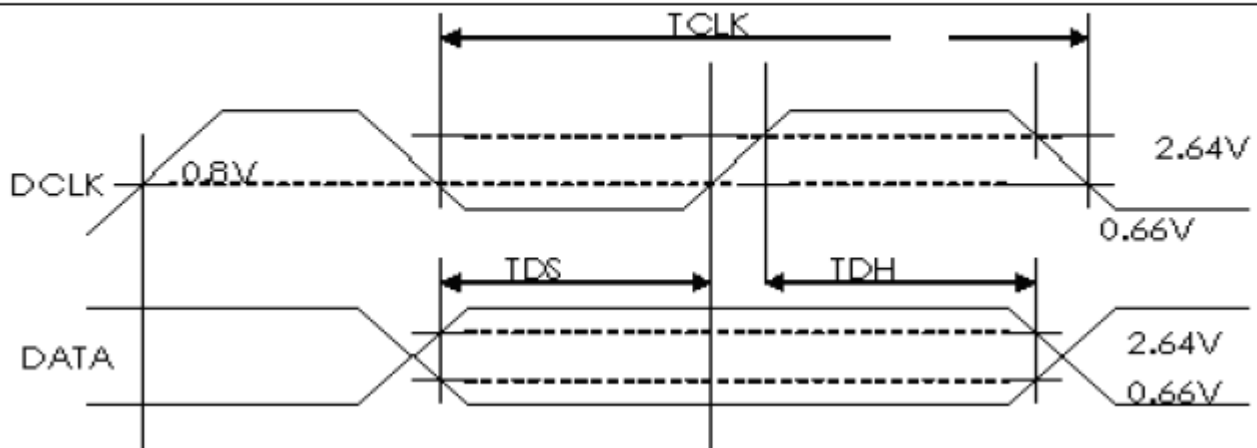
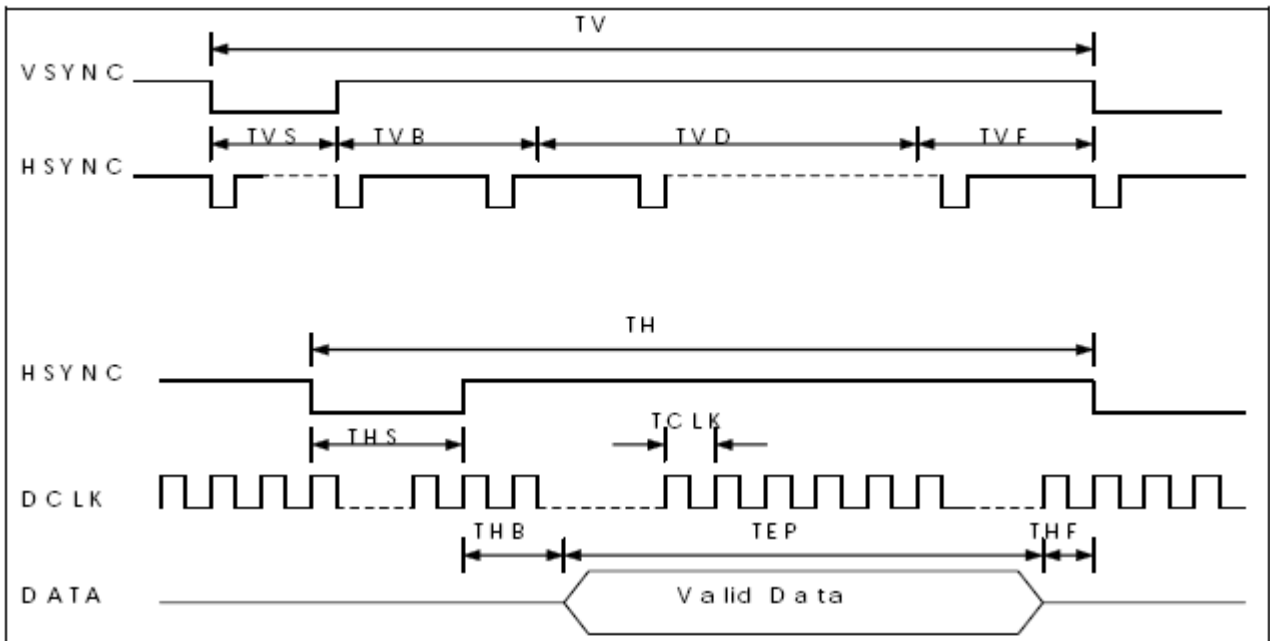
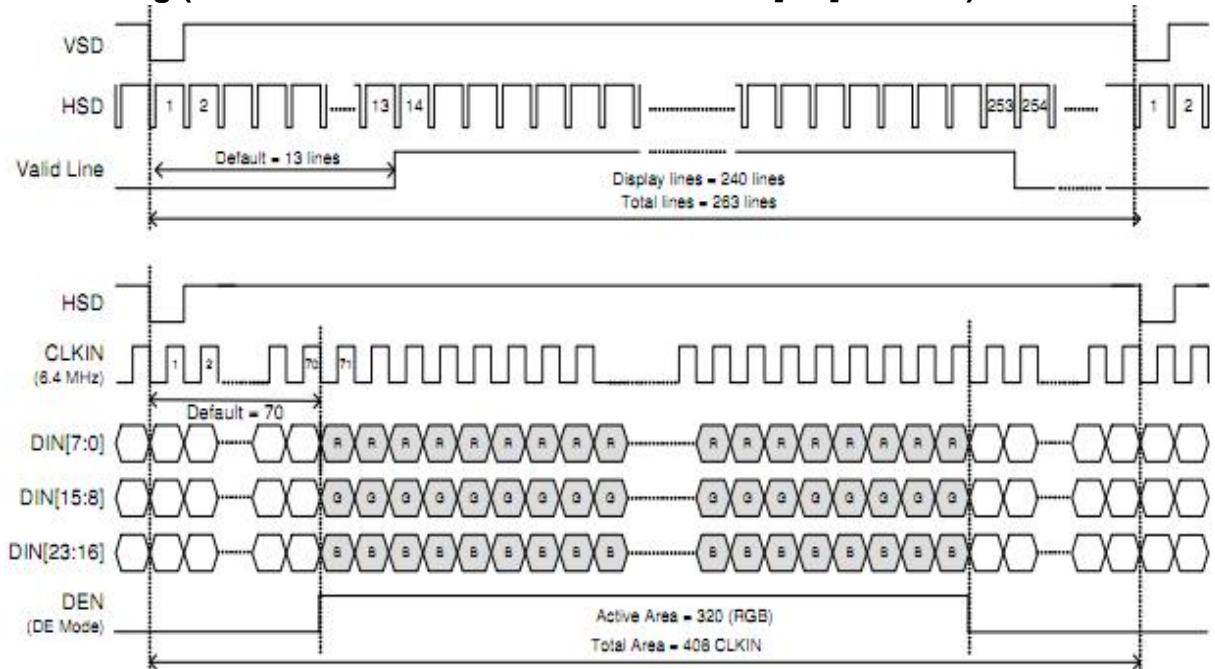

Figure 7 IHS and IVS timing waveforms



6.4 Input Data Timing (24 bit RGB mode for 960 x 240 @ SEL[3:0] = 1100b)



6.5 Vertical Timing Diagram (HV Mode)

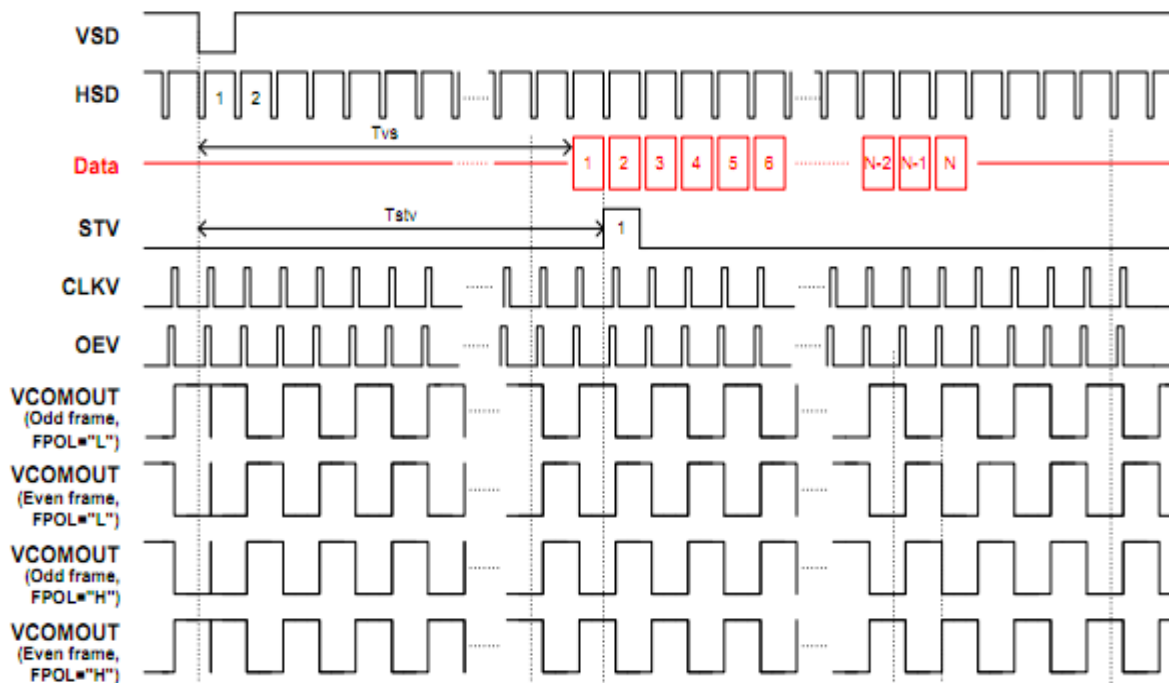

6.6 Vertical Timing Diagram (DE Mode)

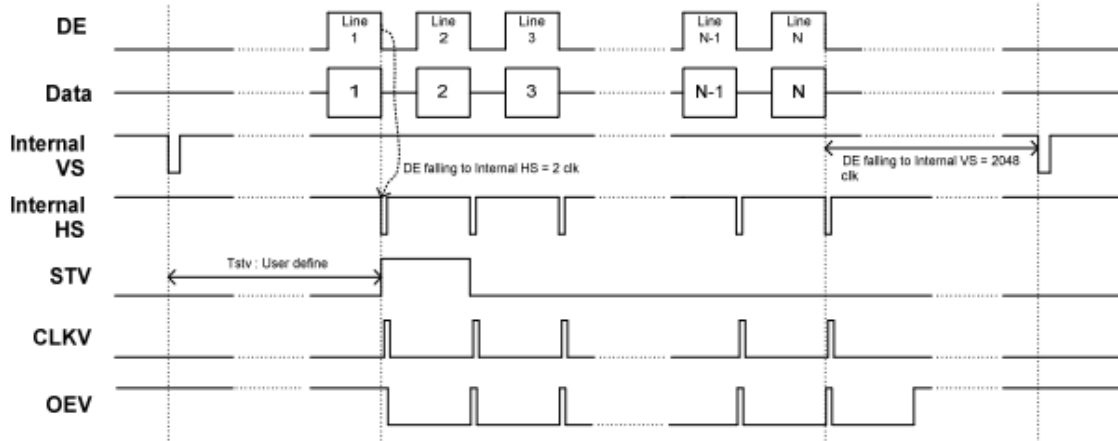

6.7 Reset Timing Chart

The RESET input must be held at least 1ms after power is stable

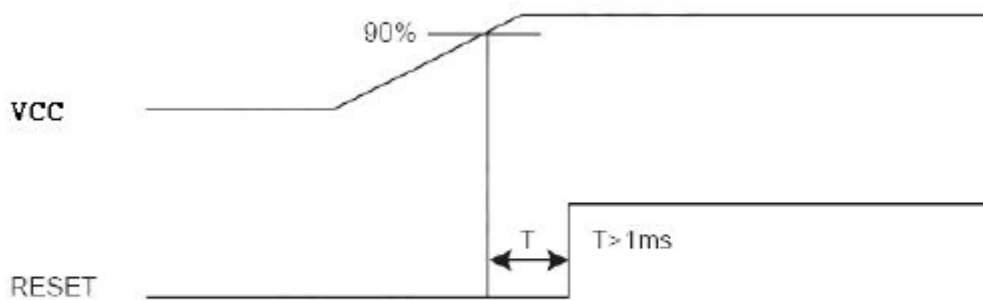

Reset timing

7 Optical Characteristics

Items		Symbol	Condition	Min.	Typ.	Max.	Unit	Remark
Viewing angles		θ_T	Center CR \geq 10		55	-	Degree.	Note2
		θ_B			65	-		
		θ_L			65	-		
		θ_R			65	-		
Contrast Ratio		CR	$\Theta = 0$	-	350	-	-	Note1, Note3
Response Time		T_{ON}	25°C	-	20	35	ms	Note1, Note4
		T_{OFF}		-	25	40		
Chromaticity	White	X_W	Backlight is on	0.282	0.312	0.342	-	Note1, Note5
		Y_W		0.319	0.349	0.379	-	
	Red	X_R		0.609	0.639	0.669	-	
		Y_R		0.314	0.344	0.374	-	
	Green	X_G		0.264	0.294	0.324	-	
		Y_G		0.557	0.587	0.617	-	
	Blue	X_B		0.102	0.132	0.162	-	
		Y_B		0.106	0.136	0.166	-	
Uniformity		U		80	-	-	%	Note1, Note6
NTSC					50		%	Note5
Luminance		L		300	350			Note1, Note7

Test Conditions:

1. IF= 20mA(one channel),the ambient temperature is 25°C.
2. The test systems refer to Note 1 and Note 2.

Note 1: Definition of optical measurement system.

The optical characteristics should be measured in dark room. After 5 minutes operation, the optical Properties are measured at the center point of the LCD screen. All input terminals LCD panel must be ground when measuring the center area of the panel.

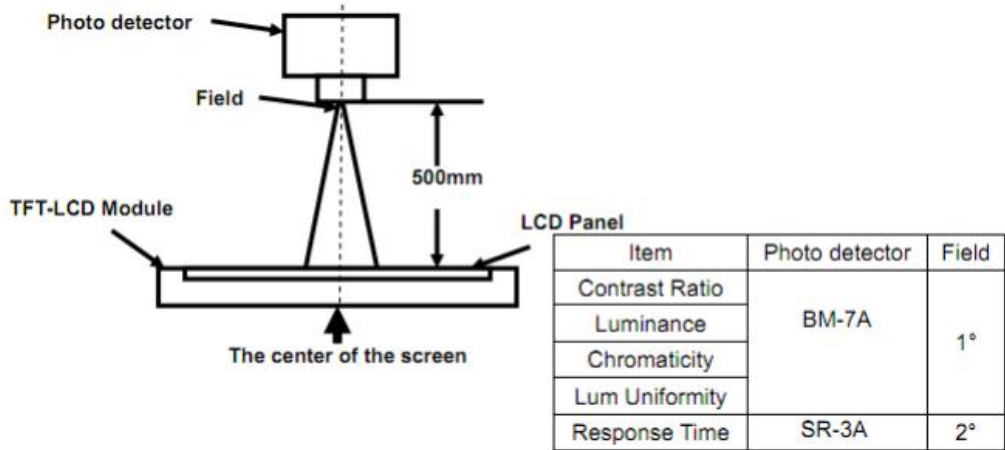

Note 2: Definition of viewing angle range and measurement system.

Viewing angle is measured at the center point of the LCD by CONOSCOPE (ergo-80).

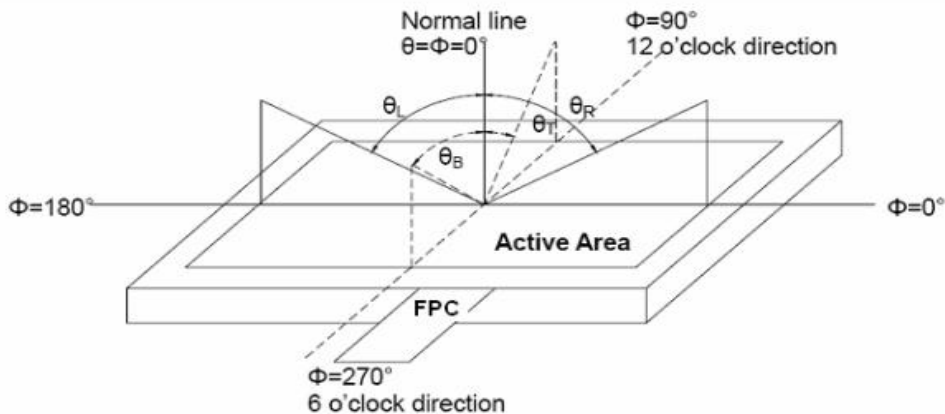

Fig. 1 Definition of viewing angle

Note 3: Definition of contrast ratio

$$\text{Contrast ratio (CR)} = \frac{\text{Luminance measured when LCD is on the "White" state}}{\text{Luminance measured when LCD is on the "Black" state}}$$

Note 4: Definition of Response time

The response time is defined as the LCD optical switching time interval Between "White" state and "Black" state. Rise time (TON) is the time between Photo detector output intensity changed from 90% to 10%. And fall time (TOFF) is The time between photo detector output intensity changed from 10% to 90%

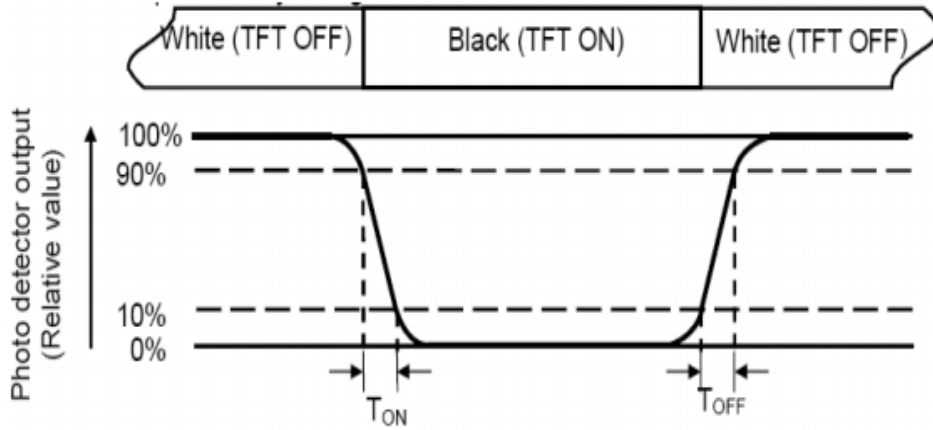

Note 5: Definition of color chromaticity (CIE1931)
 Color coordinates measured at center point of LCD.

Note 6: Definition of Luminance Uniformity

Active area is divided into 9 measuring areas (Refer Fig. 2). Every measuring point is placed at the Center of each measuring area

$$\text{Luminance Uniformity (U)} = \frac{L_{\min}}{L_{\max}} \times 100\%$$

L-----Active area length W----- Active area width

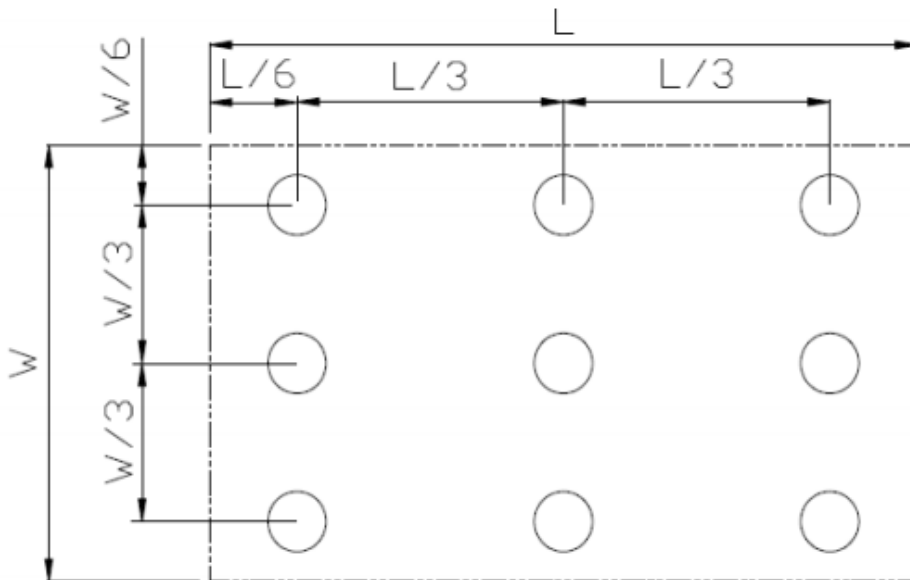

Fig. 2 Definition of uniformity

L_{\max} : The measured maximum luminance of all measurement position.

L_{\min} : The measured minimum luminance of all measurement position.

Note 7: Definition of Luminance:

Measure the luminance of white state at center point.

8 Environmental / Reliability Tests

No	Test Item	Condition	Remarks
1	High Temperature Operation	T _s = +70°C, 240hrs	Note 1 IEC60068-2-2, GB2423. 2-89
2	Low Temperature Operation	T _a = -20°C, 240hrs	Note 2 IEC60068-2-1 GB2423.1-89
3	High Temperature Storage	T _a = +80°C, 240hrs	IEC60068-2-2 GB2423. 2-89
4	Low Temperature Storage	T _a = -30°C, 240hrs	IEC60068-2-1 GB/T2423.1-89
5	High Temperature & Humidity Storage	T _a = +60°C, 90% RH max, 160 hours	IEC60068-2-3 GB/T2423.3-2006
6	Thermal Shock (Non-operation)	-30°C 30 min ~ +80°C 30 min Change time: 5min, 30 Cycle	Start with cold temperature, end with high temperature IEC60068-2-14, GB2423.22-87
7	Electro Static Discharge (Operation)	C=150pF, R=330 Ω, 5 points/panel Air:±8KV, 5 times; Contact: ±4KV, 5 times; (Environment: 15°C ~ 35°C, 30% ~ 60%, 86Kpa ~ 106Kpa)	IEC61000-4-2 GB/T17626.2-1998
8	Vibration (Non-operation)	Frequency range: 10~55Hz, Stroke: 1.mm Sweep: 10Hz~55Hz~10Hz 2 hours for each direction of X .Y. Z. (package condition)	IEC60068-2-6 GB/T2423.5-1995
9	Shock (Non-operation)	60G 6ms, ± X, ±Y , ± Z 3 times for each direction	IEC60068-2-27 GB/T2423.5-1995
10	Package Drop Test	Height: 60 cm, 1 corner, 3 edges, 6 surfaces	IEC60068-2-32 GB/T2423.8-1995

Note: 1. T_s is the temperature of panel's surface.
2. T_a is the ambient temperature of sample.

9 Mechanical Drawing

REV.	DATE	MODIFICATION
1.0	201804/29	First Issue

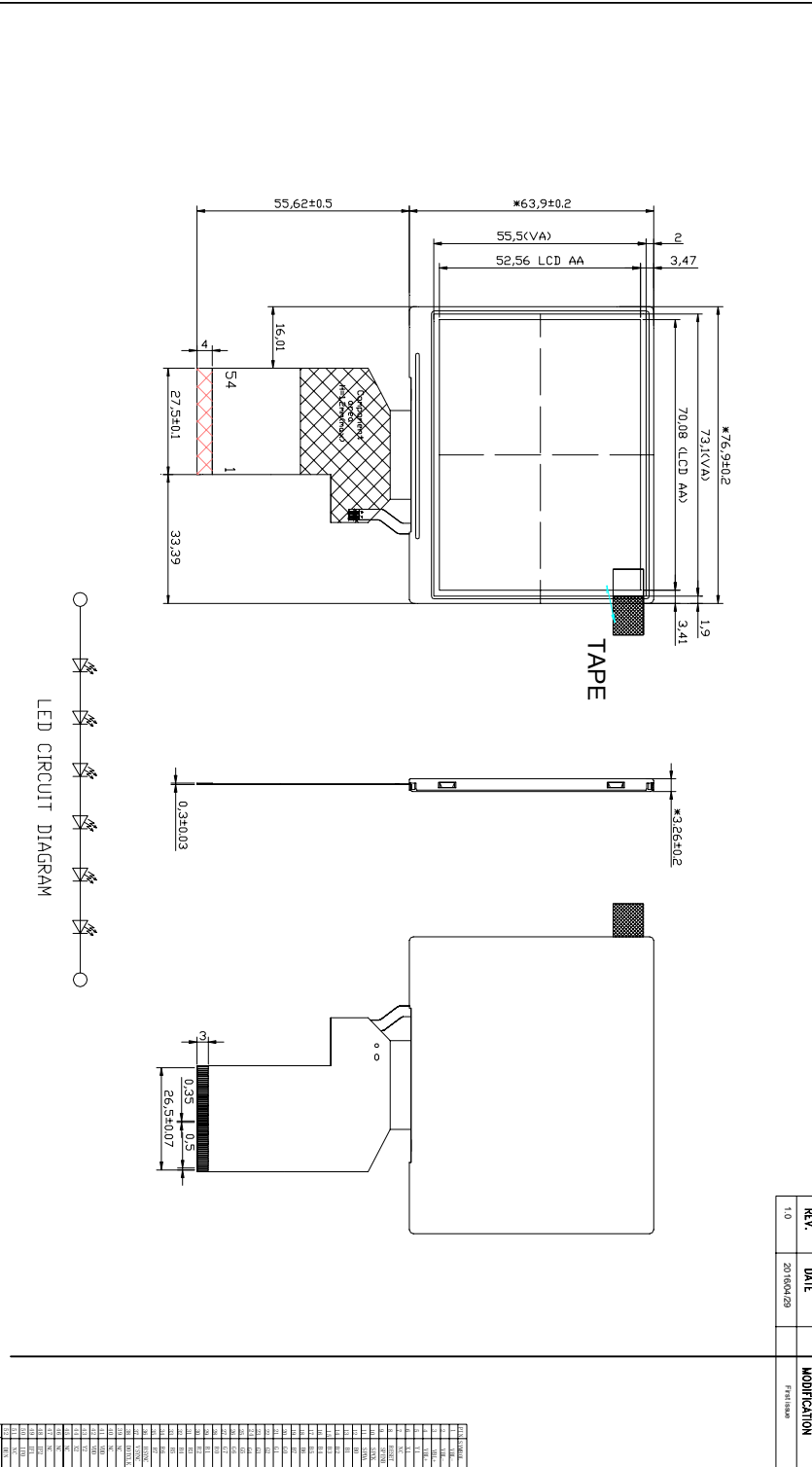

LED CIRCUIT DIAGRAM

深圳市五和天成科技有限公司 Shenzhen Wu He Tian Cheng Technology Co., Ltd.	
INTERFACE	RGB Interface
MODEL NAME	WHT38254R9S02
VIEWING DIRECTION	DMN Right/Liang
PROJECTION	3RD ANGLE
UNIT	mm
SCALE	1:1

NOTES:

1. DISPLAY TYPE: 3.5 INCH TFT TRANSMISSIVE
2. BACKLIGHT: 6 CHIP WHITE LED IN PARALLEL
3. OPERATING TEMP: -20°C~+70°C
4. STORAGE TEMP: -30°C~+80°C
5. RESOLUTION: 240X320X240
6. LCD IC:HX8298D
7. LCD IC:HX8298D
8. (*)Reference dimension; ""critical dimension
9. RoHS Compliant

1 0.Packing

Packing Method

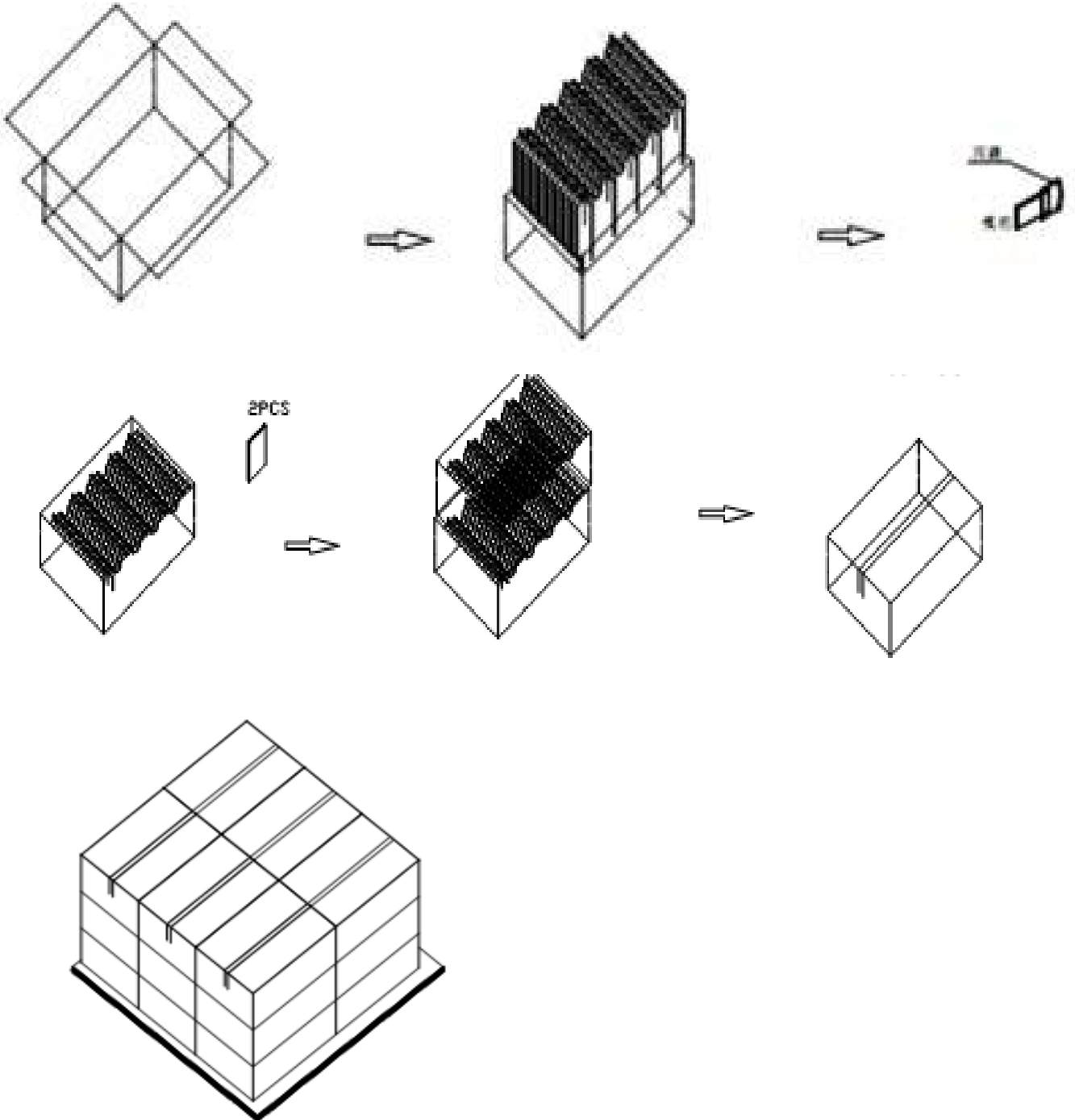

11. Precautions for Use of LCD modules

11.1 Handling Precautions

11.1.1. The display panel is made of glass. Do not subject it to a mechanical shock by dropping it from a high place, etc.

11.1.2. If the display panel is damaged and the liquid crystal substance inside it leaks out, be sure not to get any in your mouth, if the substance comes into contact with your skin or clothes, promptly wash it off using soap and water.

11.1.3. Do not apply excessive force to the display surface or the adjoining areas since this may cause the color tone to vary.

11.1.4. The polarizer covering the display surface of the LCD module is soft and easily scratched. Handle this polarizer carefully.

11.1.5. If the display surface is contaminated, breathe on the surface and gently wipe it with a soft dry cloth. If still not completely clear, moisten cloth with one of the following solvents:

- Isopropyl alcohol
- Ethyl alcohol

Solvents other than those mentioned above may damage the polarizer. Especially, do not use the following:

Water ; Ketene ; Aromatic solvents

11.1.6. Do not attempt to disassemble the LCD Module.

11.1.7. If the logic circuit power is off, do not apply the input signals.

11.1.8. To prevent destruction of the elements by static electricity, be careful to maintain an optimum work environment.

11.1.8.1. Be sure to ground the body when handling the LCD Modules.

11.1.8.2. Tools required for assembly, such as soldering irons, must be properly ground.

11.1.8.3. To reduce the amount of static electricity generated, do not conduct assembly and other work under dry conditions.

11.1.8.4. The LCD Module is coated with a film to protect the display surface. Be care when peeling off this protective film since static electricity may be generated.

11.2 Storage Precautions

11.2.1. When storing the LCD modules, avoid exposure to direct sunlight or to the light of fluorescent lamps.

11.2.2. The LCD modules should be stored under the storage temperature range. If the LCD modules will be stored for a long time, the recommend condition is:

Temperature : 0°C ~ 40°C Relatively humidity: ≤80%

11.2.3. The LCD modules should be stored in the room without acid, alkali and harmful gas.

11.3 Transportation Precautions

The LCD modules should be no falling and violent shocking during transportation, and also should avoid excessive press, water, damp and sunshine.